



Top Loading

For GN Food Pans

Model 100MPC

100MPCHL (With Hinged Serving Lid)

Features & Benefits

- Rugged and dependable, these Camcarriers provide an exact fit for a wide variety of GN Full and Fractional size Food Pans.
- Creates a wide variety of service configurations for food transporting using GN Fractional Food Pans.
- Model 100MPCHL offers a convenient serving hinge lid with easy access opening for serving directly from food pans held inside. Perfect for casual or recreational catering events and disaster relief efforts.
- Both models hold GN 1/1 Full, 1/2 and 1/3 size Food Pans without the use of Divider Bars.
- GN 1/1 Full size Food Pan capacity for both models:
 - 3 each 2½" (6,5 cm) deep
 - 2 each 4" (10 cm) deep
 - or 1 each 8" (20 cm) deep
- One-piece seamless, double-wall, high-density polyethylene construction is durable, lightweight and dishwasher safe. Textured exterior is scratch resistant.
- Foamed-in Polyurethane insulation and an airtight gasket helps to ensure excellent food temperature retention, hot or cold.
- Lids feature a passive vent slot on the underside to allow release of pressure/equalize pressure from hot items.
- Both models have six each recessed stainless steel latches.
- Molded-in handles on two sides provide comfortable, easy transporting.
- Securely stacks for more efficient transportation and storage.
- Optional Camdollies® provide easy transporting.
- Non-electrical.
- No assembly required.
- Available in 8 colors. Color variety offers quick food content identification and inventory control at-a-glance.



100MPC



100MPCHL
(Shown with Hinged Serving Lid)

Hot Holding Times / Temperatures

191°F (88°C)	186°F (86°C)	182°F (83°C)	179°F (82°C)	176°F (80°C)
Starting Temperature	1 hr.	2 hrs.	3 hrs.	4 hrs.

Cold Holding Times / Temperatures

33.8°F (1°C)	34.4°F (1,3°C)	35°F (1,7°C)	35.6°F (2°C)	36.2°F (2,3°C)
Starting Temperature	1 hr.	2 hrs.	3 hrs.	4 hrs.

Approvals



Top Loading

For GN Food Pans

Model 100MPC

100MPCHL (With Hinged Serving Lid)

Project _____

Item No. _____

Model No. _____

Quantity _____

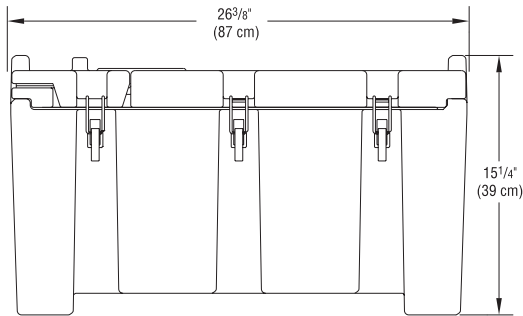

100MPCHL

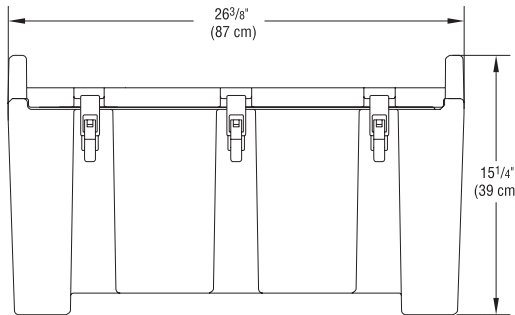
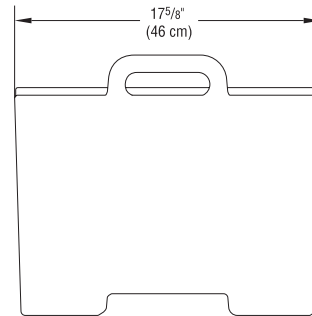

100MPC

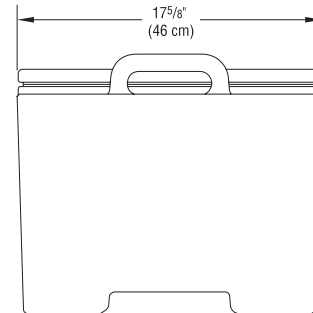

Specifications

Dimension Tolerance: +/- 1/4" (0,64 cm)

CODE	DESCRIPTION	APPROX. CAPACITY	EXTERIOR DIMENSIONS W x D x H	CASE LBS./CUBE (KG/M ³)
100MPC	Camcarrier	40 qts. (37,9 L)	26 3/8" x 17 5/8" x 15 1/4" (87 x 46 x 39 cm)	24.5 (4,51) 11 (0,13)
100MPCHL	Camcarrier with Hinged Serving Lid	40 qts. (37,9 L)	26 3/8" x 17 5/8" x 15 1/4" (87 x 46 x 39 cm)	28 (4,51) 13 (0,13)

Optional Accessories

- Camdolly®
- CD100
 - CD100H
 - CD100HB

Standard Colors

- Black (110)
- Coffee Beige (157)
- Navy Blue (186)
- Brick Red (402)
- Dark Brown (131)
- Hot Red (158)
- Slate Blue (401)
- Kentucky Green (519)

Architect Specs

The portable non-electrical GN Food Pan transport carriers shall be Camcarriers, Models 100MPC or 100MPCHL, manufactured by Cambro Mfg. Co., Huntington Beach, CA 92648 U.S.A. It shall be made of one-piece, seamless, double-wall, high-density polyethylene and foam-injected polyurethane. It shall have a passive vent slot on underside of lid to relieve or equalize pressure if needed. It shall have an airtight gasket that is easily removable for cleaning. It shall transport GN Full, Half and Third Size Food Pans, 2 1/2", 4" and 8" (6,5; 10; and 20 cm) deep. It shall not need Divider Bars. It shall have six recessed stainless steel latches. It shall have two each molded-in handles. It shall be available in a hinged lid model for serving direct from the Camcarrier. It shall stack for transport and storage. It shall be transportable with optional Camdollies®. It shall require no assembly and shall be available in 8 colors.

Approvals

